

Health is the most important factor when it comes to living a happy life.

To ensure that you use our tools safely, please observe the following information.*

* Furthermore, the relevant safety guidelines of various institutions apply, e.g. the guidelines of the trade associations, employers' instructions and the statutory specifications of the respective country.

General

- Always wear safety goggles for tasks involving chips or the possibility of parts splintering.
- Only use the hand tools for their intended purpose.
- Never modify or tamper with tools. Exceptions: Professional regrinding of chisels, scrapers, cutting tools as well as hammer edges.
- Never work with damaged tools. Damaged tools must be replaced immediately.
- Handles must be free of oil and grease.
- Depending on the task, protect your hands by wearing work gloves.
- Work on live circuits may only be performed by qualified personnel using suitable VDE tools.
- Choose a safe surface to ensure stability. Wear safety shoes.
- Wear the specified ear protection when working in noisy environments.



Tool trolley

- Read the operating instructions.
- Only open one drawer at a time. Opening several drawers at a time increases the tilting moment and the tool trolley can overturn.
- Always store the heaviest tools in the bottom (heavy-duty) drawer. Storing heavy tools in the upper drawers relocates the centre of gravity upwards which in turn increases the tilting moment. The tool trolley can overturn.
- Observe the permissible load capacity of individual drawers and the overall load capacity of the tool trolley.
- Only move the tool trolley when the drawers are closed and locked. Watch out for loose items on the shelf or working area.
- Always activate the total brake when "parking" the tool trolley. Only then is the tool trolley secured against unintentional movements.
- Always move the tool trolley facing downwards on slopes.
- Do not use the tool trolley for climbing.
- Never store pointed or sharp items loosely in the tool trolley. Scribers can be made safe by sticking them in a cork, for example.



Tool chests

- Do not use the tool chest for climbing.
- Never store pointed or sharp items loosely in the tool chest. Scribers can be made safe by sticking them in a cork, for example.
- Take care of your back by going down on your hunkers and keeping your upper body straight when lifting out the tool box.



Spanners

- Only use spanner sizes and profiles which fit the bolt or nut head.
- Do not use spanners as levers or as striking tools.
- Select the spanner in accordance with the screwed connection. This particularly applies to screwed connections with high torques.
- Never extend the tool lever arm except when the tools are designed especially for this purpose, e.g. single-ended ring spanners.
- Never hit a spanner with a hammer except when the tools have an area designed especially for this purpose, e.g. slogging spanners.
- Always apply the spanner at a right angle to the bolt axis.
- Always pull the spanner towards you. Never push the spanner away from you. If for design reasons you can only press the spanner away from you, use your open hand to prevent injuring your knuckles.
- Ring spanners transmit the forces more consistently. Ring spanners are therefore more suitable for large torques.
- Apply open-ended spanners in such a way that the angle of the jaw is facing in the direction of rotation.
- If a torque is specified for the screwed connection, use a torque wrench.
- Never work with damaged spanners. Do not repair damaged spanners but rather replace them without delay.

Why should heavy tools be stored in the bottom?

- Always store the heaviest tools in the bottom (heavy-duty) drawer.
- When the bottom drawer is opened, the centre of gravity is relocated to a safe range.
- Storing heavy tools in the upper drawers relocates the centre of gravity upwards.
- When the drawer is opened, the centre of gravity is relocated to a critical range.
- This makes the tool trolley very susceptible to lateral forces. If the trolley is exposed to lateral forces such as impact, it can overturn.
- Always observe the load capacity for each drawer to ensure that you always stay in the safe range.

S 1 = tool trolley centre of gravity when the drawer is closed
 S 2 = tool trolley centre of gravity when the drawer is opened
 red = critical range- danger of overturning

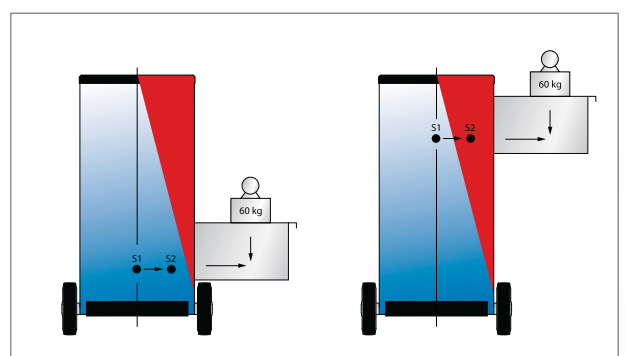



Screwdrivers

- Choose the screwdriver which is suitable for the respective bolt head profile.
- Place the workpiece on a ledge or clamp it. This helps to avoid injuries incurred by sliding blades.
- Avoid cuts by directing the requisite pressure for releasing or tightening the bolt head away from your body.
- Wear protective gloves when working with screwdrivers.
- If the screwdriver is too long, do not under any circumstances shorten the blade or handle. Choose a shorter screwdriver.
- Do not use the screwdriver as a caulking or crushing tool.
- Light hammer impact may only be applied for loosening screws using suitable screwdrivers with striking cap or continuous blade.
- If the bolt fails to loosen, use the GEDORE impact driver set no. K 1900-013 to release the bolt without destroying it.
- Insulated and tested screwdrivers must be used when working on electrical systems.



VDE tools

- Work on electrically live equipment may only be carried out by trained electricians.
- Only tools and safety equipment marked with the double triangle or bell 1000 V symbol (refer to BGV A3) may be used.
- Before commencing any work, check the insulation for damage.
- Damaged tools must not be used.
- The regulations of the employers' liability insurance associations and power supply companies must be complied with.
- GEDORE VDE tools are approved for work on live circuits at voltages up to 1000 V AC and 1500 V DC.
- Tools must not be combined unless they are designed to be securely joined together.



Pullers

- Read the operating instructions!
- Use only original spare parts and accessories for your GEDORE puller. Never use worn, modified or defective spare parts or accessories.
- Wear goggles and protective clothing when working. For added safety, use the GEDORE safety cover 5.10!
- Before pulling, ensure that the legs are in contact with the part to be pulled and are firmly tightened so that the spindle operates centrally along the axis of the puller.
- Attention! When using a puller, forces of up to several tons are generated! Take care to ensure that the puller is correctly positioned and is vertical to the component being pulled.
- Do not use electric or pneumatic power or percussion drivers.



Ratchets, tools and sockets

- Ratchets are suitable for swift releasing and tightening.
- Avoid jerky movements with the ratchet, e.g. caused by hammer impact.
- The square drive and the tool and socket square drive must be of the same size.
- Select the drive size in accordance with the screwed connection. This particularly applies to screwed connections with high torques.
- Ensure that the ball engages properly in the ball catch.
- Always pull the tool towards you. Never push the tool away from you. If for design reasons you can only press the tool away from you, use your open hand to prevent injuring your knuckles.
- Only use suitable sockets and connections for the impact driver. Use a safety pin and ring to secure the connection between the socket, extension and machine.
- When using reducers, the smaller drive's torque always applies.
- Do not use ratchets as levers or as striking tools.

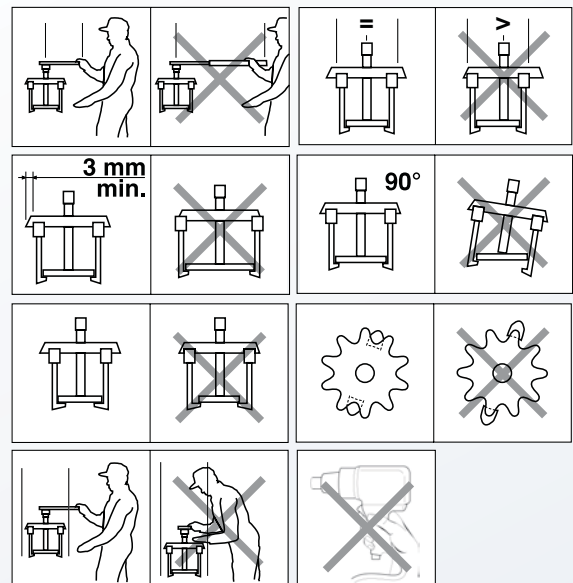



Pipe bending systems

- Read the operating instructions.
- Never use defective or worn pipe bending systems. Replace defective or worn parts with original parts.
- Use suitable systems and tools for bending.
- Wear safety goggles, safety shoes and protective clothing.
- Ensure stability of the pipe bending system during the bending process.



Safety notes for striking tools

Chisels

- Wear safety glasses and safety gloves!
- Before starting work, check that the chisel blade is sharp and the striking end is burr-free! The blades must be properly wet-sharpened!
- Select the appropriate type and size of chisel for the work to be carried out!
- Hold the chisel with a firm grip!
- When working, keep your eyes on the chisel tip!
- Wherever possible, use a chisel with hand guard.
- Never use chisels on workpieces harder than 40 HRC!
- Set safety guards in place to prevent splinters and chips posing a hazard for other people!

Centre punches, drifts and mortise chisels

- These tools are subject to the same safety rules as chisels.



Torque tools

- Read the operating instructions.
- Only use correctly calibrated torque wrenches.
- Treat torque wrenches as measuring equipment. Store torque wrenches carefully.
- Only use torque wrenches within the permissible torque range.
- Stop tightening the bolt immediately once you feel and hear the "click" signal.
- Apply the torque wrench at a right angle to the screwed connection.
- Only use original end fittings or accessories which fit the respective torque wrench.
- Where possible, do not use any reducers.
- Never loosen bolts using a torque wrench.
- Never use the torque wrench as a hammer.
- Slacken the torque wrench after completing work.
- Never use defective or worn accessory parts. Replace defective or worn parts with original parts.
- Only use one hand on the handle of the torque wrench; two-handed operation is only possible using DREMOMETER A - F.



Cutting tools

- Always set cutting tools down on a clearly visible place. Handles should always point towards you.
- Sharpen your cutting tools regularly. Blunt cutting tools represent a greater risk of injury than sharp ones. Blunt cutting tools require more force to be applied.
- Store cutting tools separately. This protects the blades and your fingers.
- Set shears down with their tips closed. This protects the blades and your fingers.



Torque Multipliers

- Read the operating instructions!
- Wear safety goggles, safety shoes and protective clothing!
- Always inspect the torque multiplier for damage before use!
- Never use electric, pneumatic or battery-operated torque multipliers or impact wrenches!
- Never exceed the specified maximum input torque!
- Always use impact sockets in accordance with DIN 3129 or ISO 2725-2 and ISO 1174!
- Always securely connect the reaction arm to the support bolt!
- Never extend the impact socket or connector between bolt and torque multiplier!
- Never use a universal or cardan joint!
- Never hit the torque multiplier with a hammer!
- Do not drop the torque multiplier!
- Never use the torque multiplier if it has been dropped, used to strike other objects, or if anything has fallen on it.
- Always keep hands and fingers away from the reaction arm!
- Always select an anchor point (wall, another bolt) sufficient to withstand torque reaction forces! Reaction torque equals output torque.
- Never allow the gearbox to touch a wall or other object!
- Never modify the reaction arm without consulting with the manufacturer!





Safety notes for hammers

- Wear safety glasses and safety gloves!
- Use the hammer only for its intended purpose!
- Never misuse the hammer as a lever!
- Before starting work, check that the hammer head is securely attached to the shaft!
- Select the appropriate type and size of hammer for the work to be carried out!
- Never hit two hammers together!
- Never use steel hammers on workpieces harder than 46 HRC! Use suitable plastic-faced hammers for this! In case of doubt, the healthier choice is a suitable plastic-faced hammer.
- Avoid bouncing blows!
- Use only the work faces of the hammer! Blows with the side face damage the non-hardened hammer eye. This can loosen the grip of the shaft in the hammer head.
- If a burr forms on the pein or face of the hammer head, this must be immediately removed. Failure to do this can pose the risk of splintering when the hammer is in use.
- Grip the hammer shaft as far away from the hammer head as possible! This improves the impact effect and avoids vibrations.
- Do not store hammers with wooden shafts in warm, dry environments! Wood is a natural product. Dry, warm storage conditions cause the shaft to lose moisture and shrink, so that the hammer shaft is no longer a tight fit in the hammer head. Opposite storage conditions also have a negative effect on the wooden shaft. Do not store the wooden shaft in too damp conditions! Too much moisture causes the wooden shaft to swell up and damages the wooden fibres. This can result in the wooden shaft snapping behind the eye area.
- Use only approved non-sparking hammers for work in explosion-hazard areas!
- Use only suitable GEDORE replacement shafts and wedges.



Safety notes

- For engines with ignition coils integrated in the spark-plug connector (coil-on-plug), use only spark-plug sockets with retainer springs! (Nos. 50 - 59)
- Do not use magnetic spark-plug spanners on coil-on-plug spark plugs!
- This can result in control unit faults!



Work gloves

- Read the operating instructions.
- Ensure that your work gloves are suitable for the respective task to be performed. Examine your work gloves for damage before use. Damaged work gloves must be replaced.
- Only work using work gloves which fit your hands perfectly.
- Store your work gloves in a clean and dry place.



Safety goggles

- Read the operating instructions.
- Ensure that your safety goggles are suitable for the respective task to be performed.
- Examine your safety goggles for damage before use. Damaged safety goggles must be replaced.
- Store safety goggles in dry areas. Use the black plastic bag provided for this purpose. This will help you to avoid scratches on the lenses.
- Clean the lenses regularly under running water, not when dry.
- Do not wear safety goggles on top of standard spectacles. Mechanical effects can be transferred which may be dangerous.



Ear protection

- Read the operating instructions.
- Ensure that your ear protection is suitable for the respective task to be performed.
- Examine your ear protection for damage before use. Ear protection displaying damage must be replaced.
- Wear ear protection for the entire duration of your stay in noisy areas.
- Store your ear protection in a clean and dry place.
- Avoid impact against the earpieces. Otherwise, this can lead to a noise level which is harmful for your ears.



Pliers

- Wear protective goggles when working with pliers! Ejected bits of wire and circlips not correctly positioned in the tip of the pliers pose a risk to your eyes!
- Check on the jaws for wear and tear! Worn jaws result in slipping and thus in accidents.
- The joint of the pliers is not to have any noticeable play! Exceptions are the sliding joints.
- When cutting wire, choose pliers that match the wire diameter and wire hardness!
- Never use pliers as hammers!
- Only insulated and tested pliers are to be used when working on electrical equipment!
- Grip wrenches are only for briefly fixing workpieces!

